

Flow Rates

The hotun sf range of dry-trap tundishes have been independently tested in a UKAS accredited laboratory by KIWA Ltd. Tested flow rates are significantly higher than the 'rated' flow rates which allows for variations in pipework layout as well as fluctuations in waste system back pressure in the event of a full bore failure. The 'rated' flow rates determine product selection and it is the responsibility of the installer to ensure that the correct product is chosen for the maximum flow rate of the installation.

FLOW L/min
(Data from KIWA)

Product	Rated flow (LPM)	Inlet size	Outlet size	FLOW L/min	
				Layout A	Layout B
hotun sf	16	15	22	22.5	12.8
hotun hiflo sf	25	15	32	45.1	35.2
hotun xlsf	40	22	32	54.3	38.1

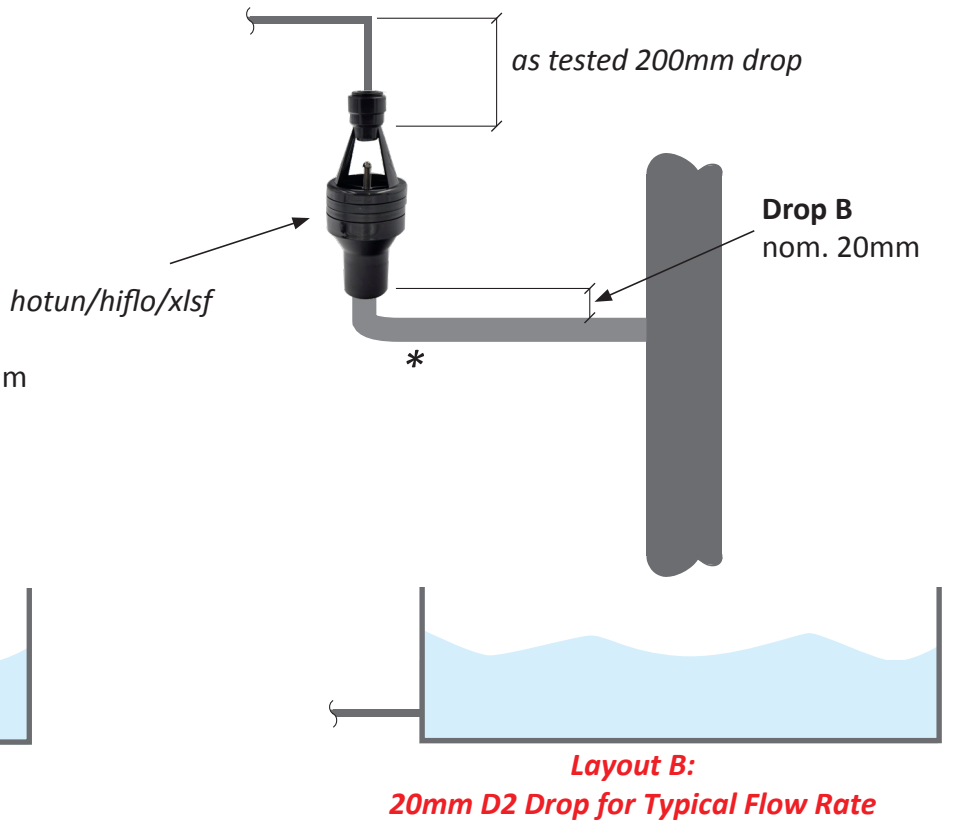
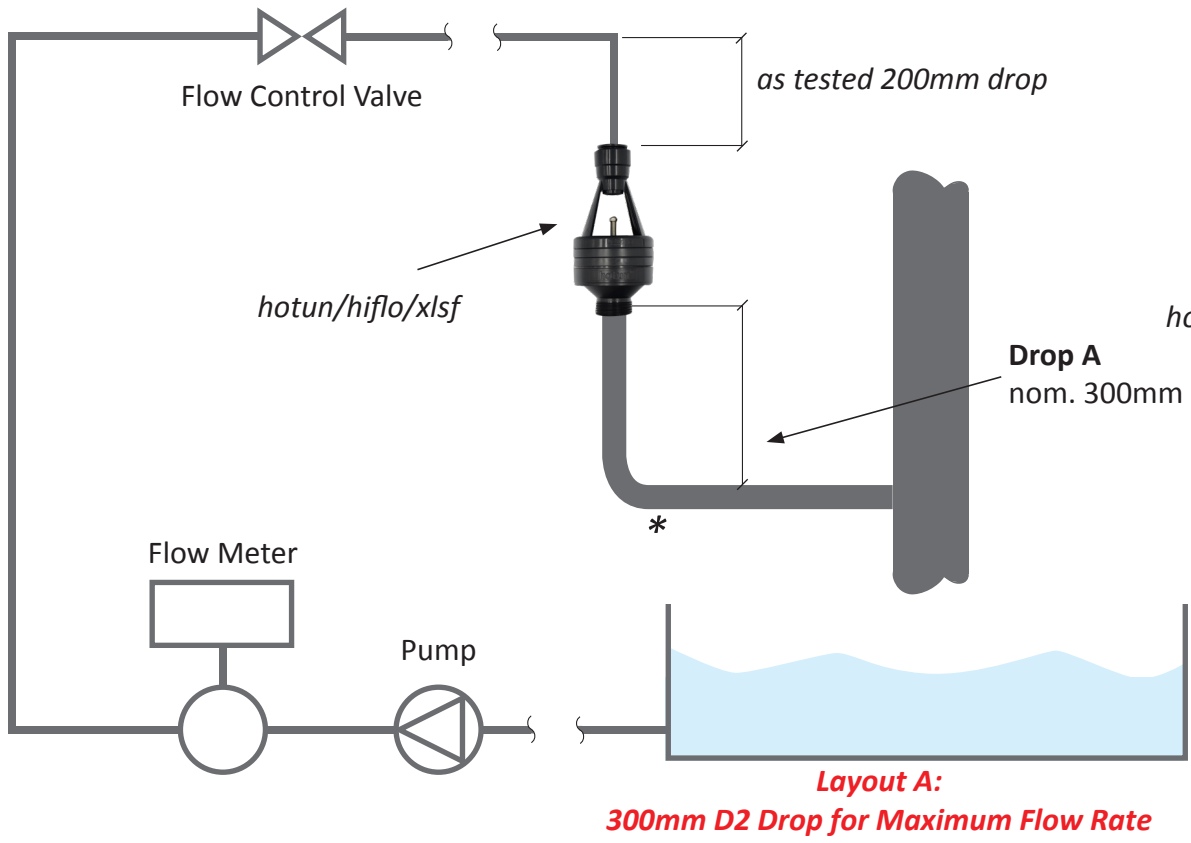

*There must not be any other forms of trap between the tundish outlet and the point of connection at the soil stack.